

Sheet: /		File: segment_board.sch	
<b>Title:</b>			
Size: A4	Date:	Rev:	
KiCad E.D.A. kicad (5.1.9-0-10_14)		Id: 1/15	

1 should look for R13/15 in charger  
 action setup  
 bal3 bc shorted

NB GND2 is not tied in to these grounds

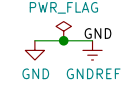

Can I actually afford a 0.1% 10mΩ resistor? They're 20x as expensive as 0.5%

C13 is the same as Cin2 and Cin3 in switcheer s

default 100mA max adapter draw before host initialization for USB power default  
 configure 3S mode

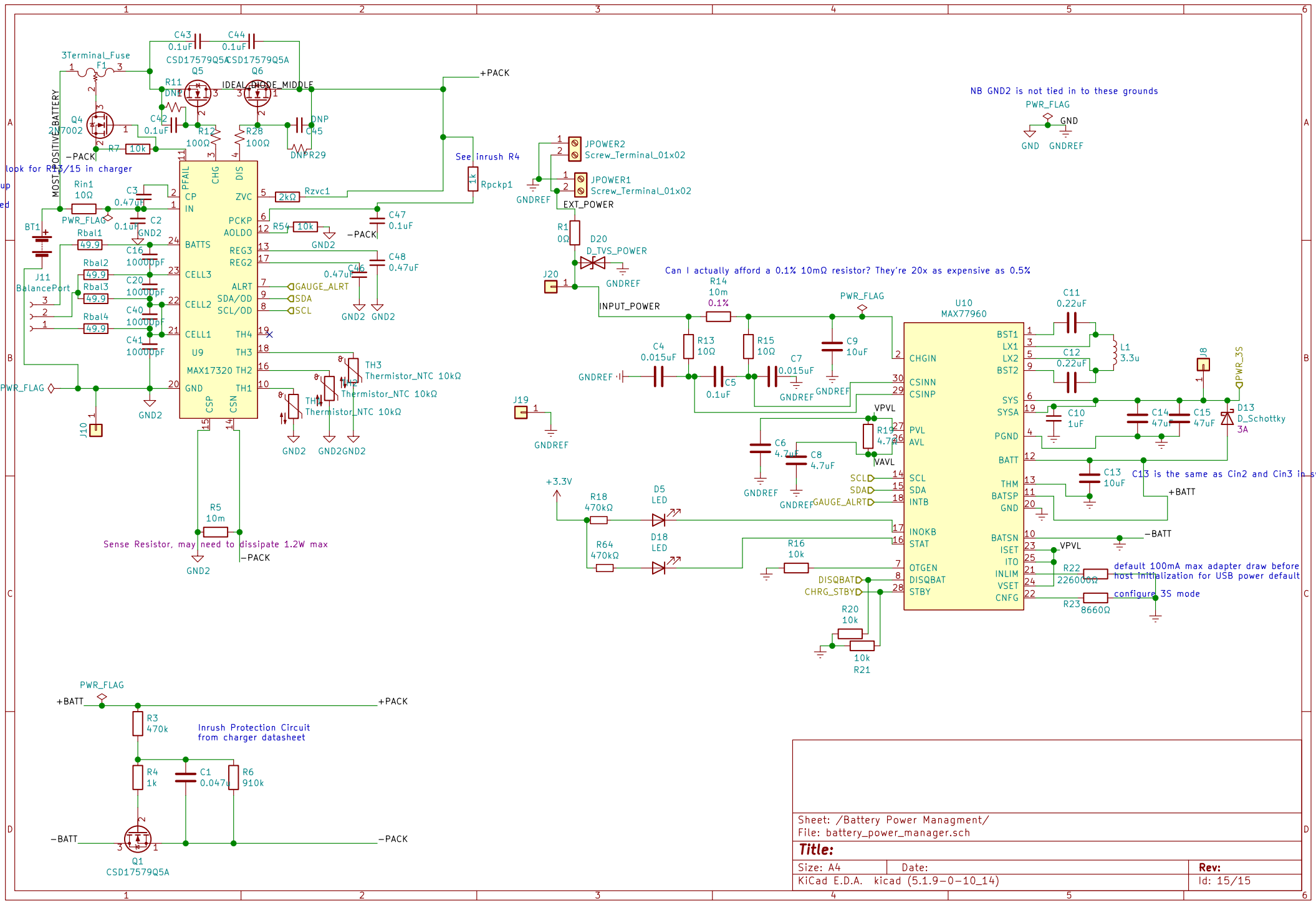

Sheet: /Battery Power Managment/ File: battery_power_manager.sch	
<b>Title:</b>	
Size: A4	Date:
KiCad E.D.A. kicad (5.1.9-0-10_14)	Rev:
	Id: 15/15

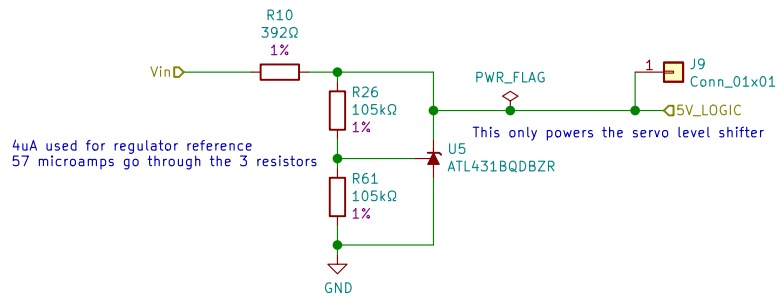
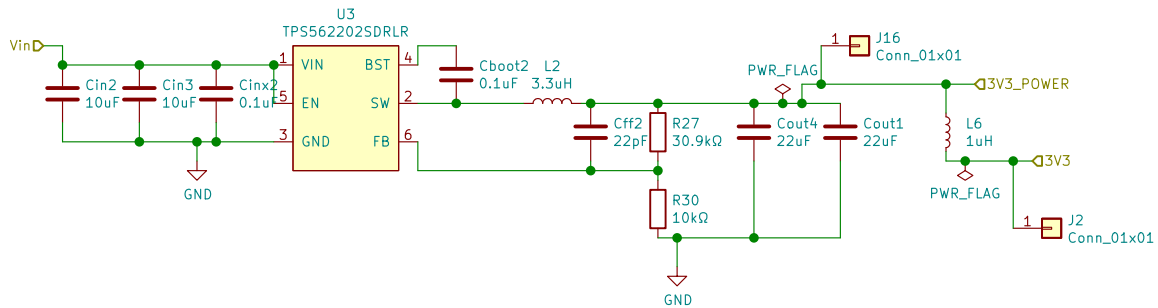
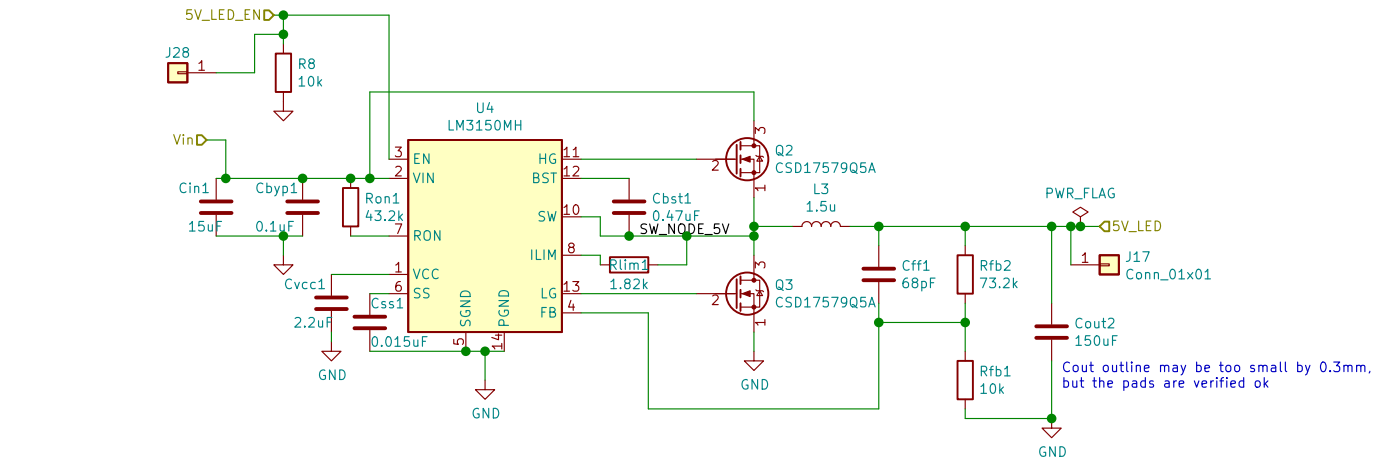

Sheet: /Power Supplies/  
File: powersupply.sch

**Title:**

Size: A4  
KiCad E.D.A. kicad (5.1.9-0-10\_14)

Date:  
Rev:  
Id: 2/15

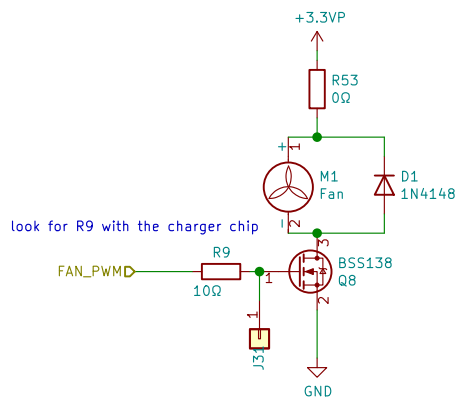

Sheet: /Fan Control Interface/  
 File: fan\_controller.sch

**Title:**

Size: A4

Date:

KiCad E.D.A. kicad (5.1.9-0-10\_14)

**Rev:**

Id: 12/15